

Application Bulletin AB-19

PROFIBUS[®] Compliance: A Hardware Design Guide

Background

Profibus is the world's most accepted field bus with over 22 million nodes in operation in 2009. It was originally developed in Germany in the 1980s and was registered as DIN 19245 in 1989. European and international standards recognize Profibus and its various interconnection formats as IEC 61784 and IEC 61158.

The generic name Profibus is derived from the term Process Field Bus. In its original form, the Profibus was designed as a low-level serial communications standard with the task of coordinating process steps via information taken from and given to the various nodes in the networked system. The original Profibus FMS (Field Management System) has been succeeded by Profibus DP (Distributed Peripherals), Profibus PA (Process Automation) and ProfiDrive, aimed solely at motor control.

Profibus DP is by far the most popular implementation of the system. This bulletin describes hardware design best practices for Profibus DP nodes. We will cover three important, although sometimes tricky, design considerations: isolation, Profibus compatibility, and bus node polarity.

Design Consideration #1: Isolation

Figure 1 shows a traditional isolated Profibus DP network node. Three isolation devices are required to successfully isolate the processor from the DP network.

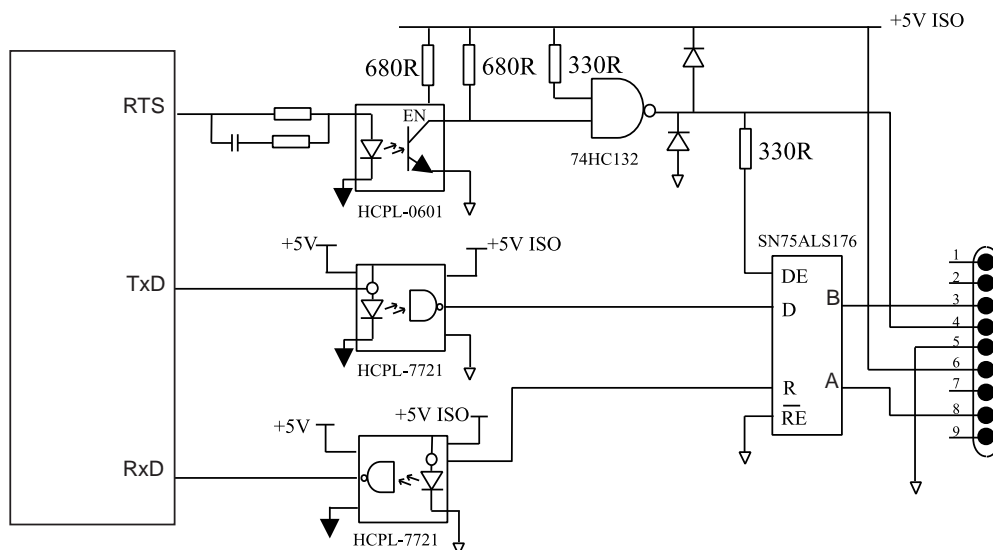

Fig. 1. Typical Profibus DP Node

This is the type of DP node you will see in all Profibus documentation, but there are much better ways to isolate the bus than using optocouplers. NVE pioneered the integration of isolation devices with Profibus transceivers to produce the IL485 Isolated Transceiver. The IL485 uses NVE's spintronic GMR isolation technology with significant advantages over optocoupler solutions. The IL485 dramatically reduces component count, improves reliability, increases tolerance to ground transients and line noise and reduces power consumption. There's also no wear out mechanism in GMR, so the device will last for the lifetime of the application without replacement. Figure 2 shows a DP node using a single-chip IL485 isolated transceiver:

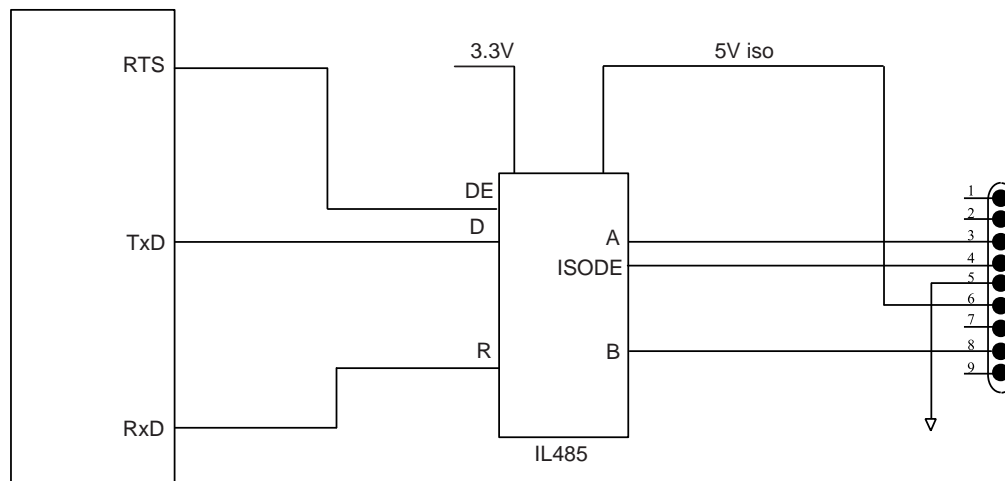

Fig. 2. Profibus DP Node using an IL485

Design Consideration #2: Profibus Approval or Compatibility

There are a great many Profibus compatible RS-485 devices on the market today. Both isolated and non-isolated transceivers are commonplace. The reality is that any RS-485 device can be connected to a Profibus node and data will be successfully exchanged on the bus. What many designers don't realize, however, is that PROFIBUS International places limits on transceiver differential output voltage that prohibit the use of many transceiver chips on the market today. If the end product is to be certified by PROFIBUS International it is very important to observe both maximum and minimum differential voltage specifications since many transceiver manufacturers believe (erroneously) that maximizing differential output voltage must be a good thing. The Profibus Specification language describing differential output voltage compounds the problem: "The differential voltage between A- and B-line shall be a minimum of 4 V and a maximum of 7 V." The problem is that RS-485 transceiver manufacturers don't specify bus voltages that way. They specify a maximum and a minimum differential voltage between A and B. Differential maximum and minimum is almost always quoted with a single output state under low and high loads respectively. Profibus quotes this specification with respect to terminal A of the bus. When A is greater than B, a negative voltage is measured with respect to A. At no load, the voltage measured will be approximately -3.2 V for most compatible transceivers. When the opposite logic state is driven from TxD, the B node will become positive with respect to A.

The voltage in this case is approximately 3.2 V for most Profibus transceivers. The differential voltage swing between A and B under these conditions is $3.2 - (-3.2) = 6.4$ V. The same measurements at maximum load should yield a worst-case differential voltage of 4.0 V.

Most manufacturers comply with the minimum value of 4.0 V, but many ignore the less obvious maximum of 7 V simply because it's relatively easy to produce devices with differential voltages of up to 8.5 V. More is definitely not better in this case. PROFIBUS International may have set the maximum specification so low to reduce noise across the DP bus.

So designers beware! Failure to use a transceiver that complies with the 4 V to 7 V differential voltage range will cause any product offered up for Profibus Certification to be rejected by the approval body. A further hurdle requires the measurement of the differential voltage to be performed at the maximum specified power supply voltage. A typical 5 V device will be specified at a maximum of 5.5 V. Profibus test laboratories use that worst-case voltage in their compliance tests.

Design Consideration #3: Sometimes Bus Node “A” Isn’t Really Bus Node “A”

The EIA-485 standard clearly labels the bus outputs as “inverting terminal A” and “non-inverting terminal B.” Most, if not all, transceiver chip manufacturers use the opposite convention where terminal A is the non-inverting terminal and terminal B is the inverting terminal. It's a great mystery why this is so, but it's important because Profibus, with typical German thoroughness, uses EIA-485 as written and labels the bus nodes as follows:

RxD/TxD-P Receive/Transmit data – Plus (B wire)
RxD/TxD-N Receive/Transmit data – Minus (A wire)

Clearly it makes no difference if data is inverted at the driver and re-inverted at the receiver, provided every DP node in the system is hooked up the same way. However, problems arise when different manufacturers produce DP nodes that use the chip manufacturer's definition of A and B output polarity. Connecting a DP node that's out of phase with the system will result in the complete malfunction of that node. This is one of the most common problems reported to the NVE applications desk. The rule is very simple; stick to the Profibus DP definition of RS-485 A and B polarity and you'll always be in sync with every other manufacturer of Profibus DP equipment.

Profibus Solutions from NVE

Since the introduction of the Profibus approved IL485 in November 2000, changes have been made to the DP differential voltage specifications that limit the use of the IL485 to existing designs. For new designs NVE recommends the IL3685. This device has improved noise margin, 15 kV ESD protection on the bus nodes, and is recognized by PROFIBUS International. Figure 3 shows a typical DP node using the IL3685:

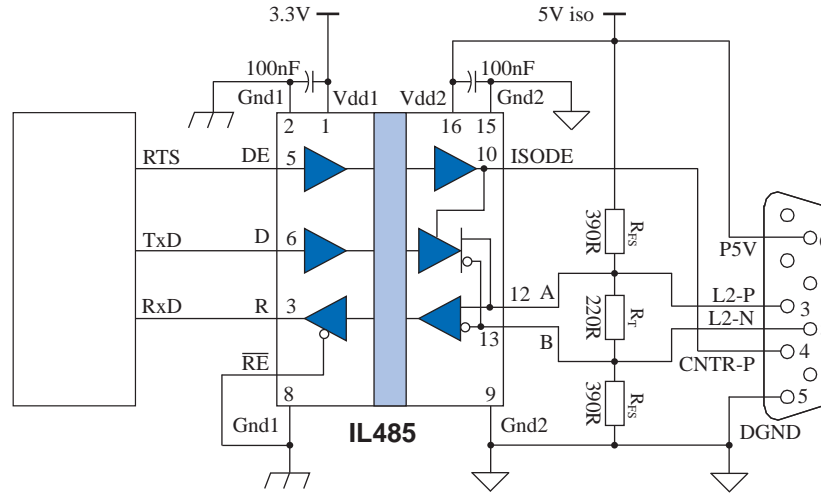

Fig. 3. Profibus DP node with IL3685

The 220 ohm termination resistor, along with another 220 ohm resistor and the other end of the bus, matches the bus impedance to minimize reflections. The 390 ohm “fail-safe” resistors guarantee a known state with no active transceivers. Bypass capacitors should be placed as close as possible to the appropriate IC.

Conclusions

There are many devices on the market that will function in a Profibus DP node. Of these, only a handful will meet the 7 V DP maximum differential voltage specification. NVE provides isolated DP bus devices that meet the specifications as laid out by Profibus, they are recognized for use in DP nodes by PROFIBUS International. Eliminate design risk, speed approvals, and get to market sooner by using NVE’s Profibus devices in all your Profibus DP applications.